

The Feature [stress]

Paul de Lacy

Rutgers, The State University of New Jersey

delacy@rutgers.edu

In:

de Lacy, Paul (2020). The feature [stress]. In Eno-Abasi Urua, Francis Egbokhare, Olùṣèyè Adéṣọlá, and Harrison Adeniyi (eds.) *African Languages in Time and Space: A Festschrift in Honour of Professor Akinbiyi Akinlabi*. Ibadan, Nigeria: Zenith BookHouse Ltd, pp. 1-27.

This article argues that lexical entries cannot contain prosodic structure. To account for contrastive ('lexical') stress, a privative feature [stress] that inhabits root nodes is proposed. Lexical stress involves preserving underlying [stress] and requiring that an output root node with [stress] must be the designated terminal element of a Prosodic Word. A prediction of this theory is that there cannot be any lexical secondary stress, unless it is mediated through derivational bases or paradigmatic uniformity. A further consequence is that there can be morphemes that contain a floating [stress] feature. Both predictions are explored, and challenges for prosodic accounts of lexical stress are identified.

*The Feature [stress]**

1. Introduction

The goal of this article is to propose that there is no underlying prosodic structure whatsoever, apart from tone: i.e. the morphs of lexical entries never contain moras, syllables, feet, prosodic word nodes, or any other node in the prosodic hierarchy. Of course, there are two obvious challenges for such a proposal: how to account for contrastive length, and how to account for contrastive ('lexical') stress.

Due to space limitations, segmental length will not be discussed here, though I believe there are compelling arguments against having moras in underlying forms. Instead, this article is entirely about lexical stress.

Many languages have contrastive stress. For example, in Cupeño words that lack long vowels, stress falls on either the first or second syllable, unpredictably.

(1) *Cupeño lexical stress* (Hill 2005:23, Alderete 1999)

(a) [ʔ.jət] *eyet* 'thief'

(b) [ʔfa.lal] *chalal* 'bark'

(c) [ʔsu.lit] *sulit* 'one'

(d) [pa. 'xal] *paxal* 'cradle'

(e) [siʔ.'qal] *si'qal* 'cover'

(f) [na.'xa.niʃ] *naxanish* 'man'

'Stress' is the phonetic realization of a phonological structure consisting of a head mora that is dominated by a head syllable that is dominated by a head foot. So, if stress is contrastive in some languages but there is no underlying prosodic structure, how is lexical stress possible?

The solution proposed here is that there is a privative segmental feature [stress] that inhabits the root node. Underlying [stress] can be preserved in output forms by using the constraint IDENT[stress] (defined in section 2). A root node that bears [stress] in the output must also be the 'designated terminal element' (DTE) of a prosodic word (PrWd) – i.e. the head root node of the head mora of the head syllable of the head foot of a PrWd (Lieberman & Prince 1977, de Lacy 2006§2.3.3.1).

For example, the underlying form of *paxal* is /paxál/, where /á/'s root node contains the feature [stress]. In Cupeño, IO-IDENT[stress] outranks constraints requiring a left-headed foot, and so the winning form is [(pa.'xál)], where ' marks the head syllable and the acute accent marks a root node with a [stress] feature. To be clear, the output still contains prosodic structure – the feature [stress] occurs in tandem with prosodic heads and constituency.

* I wrote this paper in honor of my friend and colleague, Akinbiyi Akinlabi, in celebration of his 60th birthday. As a colleague, he has helped me become a better academic and professor. As a researcher, he has greatly influenced my thinking about phonology and morphophonology (e.g. see section 4).

I suspect that the feature [stress] will not be welcomed because of an aversion to ‘representational redundancy’: the idea there should never be distinct phonological elements that are phonetically interpreted the same way. For example, Levin (1985) argues that the feature [\pm syllabic] is unnecessary because prosodic structure does the same work. However, the value of apparently redundant representation is that different representational elements can be treated as *computationally* distinct. This article will argue that [stress] and prosodic structure have different functions: [stress] enables contrast (and limits it in striking ways); underlying prosody, on the other hand, is never preserved simply because it is never present in lexical entries.

Section 2 delves into the theoretical proposal in detail. Section 3 discusses the implications of [stress] preservation for the typology of lexical stress, specifically discussing the absence of lexical secondary stress. Section 4 explores the feature-like behavior of [stress], focusing on morphemes that cause stress mutation and movement. Conclusions are presented in section 5.

2. Theory of [stress]

The idea that there is a feature [stress] goes back to the beginning of Generative Phonology (Chomsky & Halle 1968: 66ff). However, the need for a [stress] feature in SPE was motivated by the lack of prosodic structure in that theory. Here, the proposal is that there is a feature [stress] *in addition* to prosodic structure.

SPE’s [stress] feature was multivalued (p.66). In contrast, the feature proposed here is privative. While it is possible that the feature is binary [\pm stress], or even three-valued (unstressed vs. secondary vs. primary stressed), the evidence discussed in sections 3 and 4 suggests that privative [stress] can adequately account for the typological variation seen in lexical stress and stress-related morphemes.

The feature [stress] inhabits the root node, along with other major class features such as [sonorant] and [consonantal] (McCarthy 1988: 97ff). By placing [stress] inside the root node, it is predicted to behave like major class features: i.e. it should not assimilate or dissimilate in the same way as subsegmental features. (It is possible that [stress] depends on the presence of [+vocalic] – a convincing case of contrastively stressed consonants would resolve the issue, though such consonants are rare, no doubt for functional reasons).

Stress is subject to the same kind of faithfulness constraint that exists for other features. Whether the constraint is IDENT[F] or MAX[F] depends on one’s views on featural autonomy and the best expression of privativity. Here, the relevant [stress]-related constraint will be taken to be (2), following the schema in McCarthy & Prince (1999).

- (2) IDENT[stress] “Incur a violation for any pair of segments x and x' where (a) x corresponds to x' , and (b) the root node of x contains [stress], and (c) the root node of x' does not contain [stress].”

The feature [stress] must connect with a specific prosodic structure in the output. A highly restrictive theory is proposed here: i.e. that a root node that contains [stress] must be the DTE of a PrWd (Lieberman & Prince 1977, de Lacy 2006§2.3.3.1). In other words, a [stress] root node must be the head root node of the head mora of the head syllable of the head foot of a PrWd. The DTE of the PrWd is phonetically realized as having primary word-level stress.

There are a variety of ways of formally implementing the requirement that [stress] root nodes must be PrWd DTEs. One conception is that a [stress] root node that is not a PrWd DTE is uninterpretable, in the sense of de Lacy (2007). It is also possible that the requirement is violable. However, the consequences of having a [stress] root node that is not a PrWd DTE could be bizarre, or at least look like derivational opacity: a vowel that is not a DTE of a foot or PrWd would behave as if it were stressed for the purposes of phonological processes that refer to the [stress] feature. Such a loosening of the theory will be left for elsewhere; the more restrictive conception will be maintained here: a root node that contains [stress] must be a PrWd DTE.

2.1 Prosodic Theories of Stress Preservation

The alternative to having a feature [stress] is an entirely prosodic approach: lexical items would contain prosodic structure that is preserved by constraints (e.g. Alderete 1999, Revithiadou 1999). However, such prosodic theories face formal and typological challenges in dealing with contrastive stress.

Defining a constraint that preserves the ‘main stress’ prosodic structure (i.e. the PrWd DTE structure) has clearly not been easy. Many definitions of ‘IDENT-Stress’ do not provide a formally precise definition, but are “relatively informal” – it is clear what they should do, but not how they do it (e.g. Pater 2000:252).

A significant problem is that preservation of certain kinds of prosodic structure is clearly undesirable. Specifically, an empirically adequate theory must not generate ‘contrastive syllabification’. For example, no grammar has a surface contrast between [.pa.ka.] and [.pak.a.], or between [.pai.] and [.pa.i.] (holding prosodic and morphological structure constant). Luckily, contrastive syllabification is easy to prevent by either prohibiting underlying syllable structure, by banning constraints that preserve input syllable constituency, or by doing both.

However, it is necessary to go one step further to prevent contrastive syllabification: there must not be any input foot constituency, either (or constraints that preserve it). Otherwise, contrastive syllabification is easy to generate: /pukati/ and /puk(ati)/ could surface as [pu(ˈka.ti)] and [puk(ˈa.ti)] respectively, with the syllable affiliation of the [k] varying due to different underlying foot affiliation. To avoid contrastive syllabification, then, it is essential to ban input prosodic constituency up to the PrWd level, or prohibit constraints that preserve such prosodic structure.

If underlying prosodic constituency cannot be preserved, lexical stress presents a conundrum. A prosodic approach would have to separate constituency from headedness: i.e. heads (or ‘DTE’ness) of constituents would have to be preserved, but not constituency.

Even then, to avoid contrastive syllabification, mora DTE status could not be preserved: e.g. /pak^ha/ → [.pak^h.a.] vs. /paka/ → [.pa.ka.]. Similarly, syllable DTEs must not be preserved: e.g. /pa^σi^σ/ → [.pa.i.] vs. /pa^σi/ → [.pai.]. If there is no lexical secondary stress (see section 3), then foot DTEs should not be preserved, either. The only headedness relation – and underlying prosodic structure – that could be preserved, then, is the PrWd DTE – i.e. the head mora of a head syllable of a head foot. Preservation of any other prosodic structure – whether constituency or headedness – would have the undesirable consequence of permitting contrastive syllabification.

This conclusion – that only headedness can be preserved – is essentially embodied in Alderete (1999:18)’s theory of grid mark preservation, and Revithiadou (1999)’s theory of accent preservation. By using grid mark and accent notation, both theories avoid the issues that preservation of prosodic constituency encounters. However, these theories do not avoid all problems. Both preserve foot-level prominence, so /tapäu*/ could surface as [(ta.^hpa)(₁u)] while /tapäu/ would surface as [ta(^hpau)], producing a surface syllabification contrast between monosyllabic [.pau.] and disyllabic [.pa.u.].

There is a further important point to make about prosodic structure and preservation: prosodic structure *is* preserved on dimensions other than input-output. It is preserved between derivational bases and derived forms (Benua 1997:ch.5), between bases and reduplicants (Zukoff 2015), in inflectional paradigms (McCarthy 2005), and in surface correspondence (Stanton & Zukoff 2018).

So, for prosodic theories of stress preservation, there are a multiplicity of prosodic faithfulness constraints that hold of all dimensions except the input-output one; curiously, only one constraint holds between inputs and outputs: it preserves PrWd DTE status.

In contrast, in the [stress] feature theory, there are faithfulness constraints that preserve prosodic constituency and headedness along every dimension, including input-output. However, there is no underlying prosodic structure so input-output prosodic faithfulness constraints will apply vacuously. Without underlying prosodic structure, though, some other mechanism is necessary to account for lexical stress: i.e. the feature [stress].

3. [Stress] and Lexical Stress

The feature [stress] is privative and any output root node that contains it must be a PrWd DTE. In this section, preservation of [stress] is illustrated, and a consequence of the theory is explored: i.e. that there is no lexical secondary stress.

3.1 Preservation of Primary Stress

Preservation of contrastive primary stress in a grammar is driven by IO-IDENT[stress] being decisive in at least some competitions, and outranking at least some metrical constraints (see section 4.3 regarding OI-IDENT[stress]).

In Cupeño, for example, stress always falls on a long vowel if it is present. It is only when there are no long vowels in a word that stress is unpredictable: it can fall on either the first or second syllable. Largely following Alderete (1999)’s analysis, IO-IDENT[stress]

must be ranked between metrical constraints, as illustrated below. As above, an acute accent marks a root node with a [stress] feature, ' marks head syllables of PrWds, and _i marks foot heads that are not PrWd heads.

(3) *Cupeño stress ranking, simplified*

(a) Stressing heavy syllables beats stress preservation

/síβu:ru/	ALLFTL	STRESSHEAVY	ID[stress]	TROCHEE
☞ (a) (si.'βu:)ru			*	*
(b) ('sí.βu:)ru		*!		

(b) Left alignment beats stress preservation

/patakán/	ALLFTL	STRESSHEAVY	ID[stress]	TROCHEE
☞ (a) ('pa.ta)kan			*	
(b) pa(ta.'kán)	*!			*

(c) Stress preservation emerges

/paxál/	ALLFTL	STRESSHEAVY	ID[stress]	TROCHEE
☞ (a) (pa.'xál)				*
(b) ('pa.xal)			*!	

(d) Stress preservation accords with default stress

/tʃálal/	ALLFTL	STRESSHEAVY	ID[stress]	TROCHEE
☞ (a) ('tʃá.lal)				
(b) (tʃa.'lal)			*!	*

There are no candidates like [(¹pa.xál)], where the [stress] root node is not the PrWd DTE – either GEN does not generate them, or they are rejected by the interpretive component (de Lacy 2007). It is possible – and assumed above – that not all PrWd DTEs must also have a [stress] feature, though the consequences of having a winner with a PrWd DTE without a [stress] feature will have to be explored elsewhere.

3.2 Lexical Secondary Stress

The theory of [stress] presented above does not allow for preservation of ‘secondary stress’ – i.e. preservation of foot DTEs that are not the heads of PrWds. The requirement that a [stress] root node must be a PrWd DTE effectively prevents such preservation. In practical terms, no language will have two lexical output forms that differ solely in the presence of secondary stress: e.g. [¹pa.ka._ite] ‘cat’ vs. [¹pa.ka.te] ‘dog’.

The claim that there is no lexically contrastive secondary stress is found in van der Hulst (1994), but is disputed by Alderete (1999:24). Alderete (1999)’s counter-examples are examined below, with several additional cases.

The challenge in identifying lexical secondary stress is that there are several mechanisms that produce something that looks like contrastive secondary stress: metrical alignment with morpheme boundaries, category-specific metrical conditions, PrWd parsing, and transderivational faithfulness. Such cases will be illustrated below. This

section will conclude with a discussion of what real lexical secondary stress would look like.

A caveat to this discussion is how secondary stress is detected: in many cases, it seems that a secondary stressed syllable (i.e. a foot DTE that is not a PrWd DTE) has no special acoustic realization – its status can only be detected through head-sensitive (morpho-)phonological processes (e.g. vowel reduction, fortition, infixation to prosodic heads). Without such head-sensitive phonological processes, the evidence for secondary stress is usually impressionistic, with all the caveats that go with such evidence (e.g. de Lacy 2009).

- *Class-specific metrical conditions*

Different lexical classes can have distinct phonological – including metrical – restrictions (Itô & Mester 1995, Smith 2002, Inkelas & Zoll 2007).

For example, in Lynch (1978)'s description of Lenakel (Tanna), secondary stress falls on alternating syllables in nouns, arrayed right-to-left from the main stress: e.g. [tu.₁p^wa.lu.¹ka.luk] 'lungs'. However, in verbs and adjectives, secondary stress starts at the left edge: e.g. [₁ni.ma.rok.¹kej.kej] 'he liked it'.

In Optimality Theory, Lenakel nouns and verbs/adjectives cannot be analyzed as having different underlying secondary stresses because secondary stress is entirely regular, differing predictably based on part of speech. Due to Richness of the Base, one must ask what would happen to verbs with underlying secondary stress on their second vowel; the answer is, of course, that it would be ignored and secondary stress would proceed from left to right. For further discussion of Lenakel, see Hayes (1995§6.1.8), where a category-specific metrical rule is proposed.

A very similar situation is found in Huariapano, which has been claimed to have lexical secondary stress (Alderete 1999:24). The following discussion is based on Parker (2013)'s impressionistic description. There are two classes of words – called 'L' and 'R' here. Primary stress works in the same way for both classes: it falls on a final heavy syllable, otherwise on the penult: e.g. [ka(¹no.ti)] 'bow (weapon)', [ja(₁wiʃ)] 'opossum'. In foot terms, Huariapano has a final quantity-sensitive trochaic head foot. (A few words have final or antepenultimate main stress).

However, secondary stress is different for each class. For L class words, secondary stress falls on the initial syllable and on every other syllable up to (but not adjacent to) the primary stress: e.g. [₁muu.raj.βa.¹ʃi.ki] 'we found'. However, in the R class, secondary stresses start at the primary stress and fall on alternating syllables left to right: e.g. [mi.₁βom.bi.¹ra.ma] 'you (plural)', [a.₁ri.βah.¹kaŋ.ki] 'they repeated'.

The Huariapano situation, then, is similar to Lenakel's: Huariapano's L class words behave like Lenakel verbs/adjectives and R class words behave like Lenakel nouns.

The difference between Lenakel and Huariapano is that there is no clear morphosyntactic difference between the L and R classes. Membership is synchronically

arbitrary, just like English dialects' Latinate and Germanic lexical classes (e.g. Fabb 1988), or masculine and feminine classes in Romance languages.

However, instead of an analysis with class-specific metrical conditions, would it be possible to analyze the difference in Huariapano words as involving a difference in underlying secondary stress? Parker (2013:18) directly addresses this question, observing that whether a word has leftwards or rightwards feet depends on the root, yet the root itself does not necessarily end up with secondary stress in the same place: e.g. [ra.ku] 'fear', [rah.ku.¹a.naj] 'to be afraid', [rah.ku.tʃa.¹i.ki] 'it's scary' (the root is underlined). Parker (2013:19) comments that, consequently:

“... it would be futile to construct an underlying metrical foot [PdeL: i.e. secondary stress] somewhere in the lexical entries of roots of this type since it is impossible to predict *a priori* where the secondary stress will surface. Rather,...these Huariapano patterns necessitate an analysis whereby parallel co-phonologies [PdeL: i.e. class-specific conditions] are posited for the same language”.

Bennett (2013) proposes another analysis of Huariapano where the difference between word classes is not direction of footing, but type of foot: class L has trochees while R has iambs. For present purposes, Bennett (2013)'s analysis makes the same point as Parker (2013)'s: secondary stress cannot be marked underlyingly – it is foot *type* that distinguishes the two classes, not location of foot heads.

- *Bases and pseudo-bases*

Kenyon & Knott (1953)'s description of American English has apparent lexical secondary stress: compare [₁pɪg.mən.¹teɪ.ʃn] 'pigmentation' with [₁kən.dən.¹seɪ.ʃn] 'condensation'. The second syllable in *pigmentation* is not stressed (and so the vowel reduces), while the second syllable in *condensation* has secondary stress (and does not reduce). There are a number of words of both types (e.g. no stress: *segmentation*, *transformation*; stressed: *condensation*, *importation* – see Pater 2000:251 for discussion and references).

However, *condensation*-like forms have been argued to not exhibit lexical secondary stress, but rather show preservation of their base's primary stress: e.g. the derivational base of *condensation* is *condense* [kən.¹dens], and the stress on [¹dens] is maintained in the derived form (Chomsky & Halle 1968, Pater 2000). Such output-output faithfulness to prosodic structure is perfectly admissible in the current theory: recall that the prohibition proposed here is on prosodic structure in inputs (i.e. lexical entries). While there are faithfulness constraints that preserve prosodic structure, they cannot apply on the input-output dimension because the input does not contain any prosodic structure. However, they can apply on the base-derived form (output-output) dimension (Benua 1997; and any other dimension – base-reduplicant, surface-surface, inflectional paradigm).

Even so, there is an apparent problem with forms like [₁ɪn.kɑɪ.¹neɪ.ʃn] *incarnation* and [₁ɔ.¹stɛn.¹teɪ.ʃn] *ostentation*. *Incarnation* should be *[₁ɪn.kɑɪ.¹neɪ.ʃn] – the only reason

for pre-tonic secondary stress to occur here is that it preserves a primary stress in its derivational base. However, there is no independent base *incarn* [ɪn.'kɑm], nor is there a base *ostent* [ɔ.'stent]. So, how can the pre-tonic secondary stress be due to output-output faithfulness?

The solution involves pseudo-bases. In some languages, there are words that behave as if they consist of a root with affixes, but no independent root exists. An example is the Māori verb *titiro* [titiro] ‘examine’. When reduplicated verbs are suffixed, they drop their reduplicants (Bauer et al. 1993:516). So, *titiro* becomes *tirohia* [tirohia] ‘*titiro*+passive’, not *[titirohia], and [tirohaŋa] ‘*tiro*+gerund’, not *[titirohaŋa].¹ However, for at least some speakers, there is no independent morpheme *tiro* – only *titiro*. In other words, for affixation purposes *titiro* is treated as if it consisted of a prefixal reduplicant and a root even though there is no root *tiro*. Zuraw (2002) provides similar examples from Tagalog.

So, in American English there are pseudo-bases *incarn* /ɪnkɑm/ and *ostent* /ɔstent/. They are realized as [ɪn.'kɑm] and [ɔ.'stent], and *incarnation* and *ostentation* preserve their pseudo-base’s main stress. The interesting issue with pseudo-bases is why a learner would add such entries to their lexicon when they do not ever encounter them independently; clearly, learners must be capable of deducing the existence of lexical items based on their apparent inclusion in attested morphologically complex items.

Halle & Kenstowicz (1991) argue that there are actually two different classes of words, and that the *condensation/incarnation* class has a specific condition that requires stress on heavy syllables. However, Liberman & Prince (1977:299) and Pater (2000:252) observe that proposing class behavior misses the generalization that the exceptional pre-tonic secondary stress depends on the existence of primary stress in the corresponding location in the base. To put it slightly differently, exceptional pre-tonic secondary stress *only* occurs when there *is* or *could be* a base which has primary stress in that position, thus requiring pseudo-bases (c.f. Pater 2000:252, which assumes that *incarnation* words have a lexical secondary stress).

- *Pseudo-compounds and multiple PrWds*

In certain situations, single morphs can be parsed into multiple PrWds. When they do, they behave phonologically like compounds, and the multiple PrWd structure can be mistaken for secondary stress.

For example, Fijian has a maximum size restriction on its PrWds: they cannot be large enough to contain two feet, so they are never larger than three syllables (this condition may well be common to all Central Pacific languages: de Lacy 2004, Ketner 2006). As shown in (4), long strings are parsed into several PrWds. In Fijian compounds, the rightmost PrWd is the head, so the head syllable of the head PrWd is marked with a double accent (^l). The prosodic parsing here is my own; the data is adapted from Schütz (1978).

¹ More precisely, verbs with passives other than *-tia* drop initial CV reduplicants, for good prosodic reasons: cf. [ha-hae-tia] ‘be slit’, [hi-hiri-tia] ‘be checked’. See de Lacy (2004, 2017) for discussion and references.

(4) *Fijian pseudo-compounds*

- | | |
|--|--|
| (a) [{{'mini}}{si''ta:}}] ‘minister’ | (e) [{{pa'lasi}}{''ta:}}] ‘plaster’ |
| (b) [{{'ota}}{ka''risi}}] ‘watercress’ | (f) [{{pe'resi}}{''te''di}}] ‘president’ |
| (c) [{{'koni}}{ta''raki}}] ‘contract’ | (g) [{{te'reni}}{'sisi}}{''ta:}}] ‘transistor’ |
| (d) [{{'para}}{ka''raβu}}] ‘paragraph’ | |

Crucially, there are lexical distinctions in PrWd parsing. Compare ‘minister’ with ‘plaster’: the former consists of two disyllabic PrWds while the latter has a trisyllabic PrWd followed by a monosyllabic one.

The present theory provides a way to account for such lexical differences by having different underlying [stress] locations: ‘minister’ is /mínisita:/ while ‘plaster’ is /palásita:/. To preserve underlying [stress], keep PrWds adequately small, and have default footing (a rightmost quantity-sensitive trochee), /mínisita:/ is necessarily realized as [{{'míni}}{si''ta:}}]; *[{{mi'nisi}}{''ta:}}] is impossible because [stress] is not preserved. In contrast, ‘plaster’ must be parsed as [{{pa'lási}}{''ta:}}], not the unfaithful *[{{'pala}}{si''ta:}}].

How are pseudo-compounds relevant to lexical secondary stress? Pseudo-compounds are occasionally misanalyzed as consisting of a single PrWd, so that the component PrWds are thought to be secondary stresses. For example, Hayes (1995:143-4) reports [{{(,mini)si('ta:)}}] and [{{pa(,lasi)('ta:)}}]. With such stressing, it looks as if *minister* and *plaster* differ solely in the placement of a lexical secondary stress. However, the underlying [stress] root nodes actually appear in the DTE of a PrWd, as required by the present theory.² Importantly, there is no need for underlying secondary stress.

Finnish also has single morphemes that behave like compounds, giving the effect of lexical secondary stress. Kiparsky (2003:113) identifies two relevant word types: (a) ‘movable’: e.g. *Kálevàla* cf. *Kálevàlâ-ssa* ‘Kalevala’, and (b) ‘fixed’: *Álabàma* cf. *Álabàma-ssa* ‘Alabama’. The fixed type are called ‘quasi-compounds’: this type’s secondary stress often initiates a vowel harmony domain, while the movable type’s secondary stress “very seldom” does. Kiparsky (2003)’s analysis is that the fixed forms (at least when suffixed) consist of two PrWds (e.g. {*Ála*}{*bámassa*}), while movable forms have one (e.g. {*Kálevàlâssa*}). In present terms, *Alabama* has underlying [stress] on its third /a/. To both preserve underlying [stress] and have head feet be leftmost in the PrWd, *Alabama* breaks into two PrWds: [{{*Ála*}}{*bámassa*}], *[{{*Álabamàssa*}}], *[{{*Alabámassa*}}]. As with Fijian, there is no underlying secondary stress: the different surface secondary stresses in the movable and fixed types follows from their different PrWd structure.

² Another analytical option is that the words in (4) are single morphemes with *two* morphs. So, *minister* is stored in the Lexicon as having two morphs /mini/ and /sita:/, while *plaster* is /palasi/ and /ta:/. Each morph is assigned its own PrWd (as is regular for Fijian). It is well know that single morphemes can have multiple morphs (e.g. circumfixes). Again, with such an analysis, there is no need for lexical secondary stress.

- *Other lexical stress preservation cases*

In some cases, [stress] can be realized as secondary stress in compounds, but only via faithfulness to a base form (as in American English *condense~condensation*).

For example, Gouskova (2010) argues that Russian compounds do not have recursive PrWd structure, yet preserve lexical stress as secondary stress under certain conditions: e.g. /vʲér-o-iz-po-vʲed-án-ij-o/ → [((vʲè)r-ə-is.pə(vʲi'dá)nʲijə)], *[[vʲər-ə-is.pə(vʲi'dá)nʲijə]]. While an underlying [stress] appears in the output as a foot DTE but not a PrWd DTE, the location of the secondary stress of the first root must be due to output-output faithfulness, not input-output faithfulness. In other words, underlying [stress] can appear as secondary stress in the output, but only if it is mediated through base-identity.

The same point can be made for apparent lexical secondary stress in Tübatulabal (cf. Alderete 1999:24). In Voegelin (1935)'s description, main stress falls on the final vowel of the PrWd and secondary stress falls on every other syllable going leftwards from the main stress: e.g. [ɪmbiŋwibaʔat] 'he is wanting to roll string on his thigh', [pi,tɪtpi,tɪ:di'nat] 'he is turning it over repeatedly' (V76). However, some roots always have stress on their final vowel: e.g. [kɔtu'ga-t] 'the firewood', [kɔtu,ga-'t-a] {obj.}; [tɔgum'ba-l] 'the beads', [tɔgum'ba-l-a] {obj.}; [tugu'wa-n] 'his meat', [tugu,wa'jin] {obj.} (V78). For at least *firewood* and *meat*, such preservation leads to the root's primary stress being a secondary stress in derived forms: /kɔtugá-t-a/ → [kɔtu,gá'ta]. However, it is clear that this effect is due to preservation of the derivational base's (i.e. [kɔtu'ga-t]) primary stress rather than preservation of the underlying stress because *only* the stresses that are primary in derivational bases are preserved (at least in the examples provided).

Özçelik (2014:231-2) proposes that pre-stressing suffixes can result in multiple lexical stresses in a word in some dialects of Turkish. As pre-stressing suffixes involve preservation of an underlying [stress] feature (see section 4 below), a form like [din'le-me-di-de] (where both [me] and [de] cause pre-stressing) seems to involve preservation of a [stress] feature that is realized as secondary stress – i.e. on [di].

However, Kabak & Vogel (2001) propose that pre-stressing suffixes in Turkish actually introduce a PrWd boundary, similar to class II suffixes in English dialects. In the dialect described in Kabak & Vogel (2001), there is only one stress per word (or, at least, secondary stress position is controversial). So, the word cited above would have the PrWd structure [{{din'le}medide}]. In this vein, the difference in the Özçelik (2014) dialect would be that each pre-stressing suffix initializes a new PrWd, each PrWd has its own head, and the leftmost PrWd is the head of its structure: i.e. [{{din''le}{me'di}de}].

Finally, Alderete (1999:24) identifies Bolozky (1982)'s description of Modern Hebrew as involving lexical secondary stress. Main stress typically falls on the final syllable, with alternating secondary stresses propagating leftwards (e.g. [ame,vuga'rim] 'the adults'). However, for five syllable words with exceptional penultimate main stress, there are two possible realizations: e.g. [keʃea'melex]~[keʃea'melex] 'when the king'. The initial-stressed form is "more typical" utterance-initially, and the peninitial-stressed form

is found “commonly” elsewhere. As the initial stress pattern is conditioned by environment, it clearly does not involve contrastive secondary stress.

However, Bolozky (1982:277) notes that “in some of these nouns ONLY the first syllable can be stressed in [utterance-]initial position”, citing “??[#ve₁afo'teret] ‘and the policewoman’ ~ [#veafo'teret]”. Even so, it is far from clear that such forms require underlying specification of secondary stress. It may be the case that there is a difference in frequency between initial- and peninitial-stressed forms in utterance-initial position, and that frequency may depend on the identity of individual words. However, there is no clear evidence of a categorical ban on peninitial stress for specific words, and that such words contrast with other words that have freer secondary stress. Modern Hebrew deserves further investigation.

- *Convincing evidence for lexical secondary stress*

Putative lexical secondary stress can be mimicked by faithfulness to stress in derivationally-related forms (including pseudo-bases), pseudo-compounds, PrWd formation that is sensitive to morpheme (and pseudo-morpheme) boundaries, and class-specific metrical behavior. If all of these factors are taken into account, what would a convincing case of lexical secondary stress look like?

An example would be a language with three different roots with the forms [₁σσ'σ], [σ₁σ'σ], [σσ'σ] (appropriately controlling syllable shape). If pseudo-bases and -morphs are ruled out, it would not be possible to claim that the variation in secondary stress is due to different morphological boundaries. While it is still possible to argue that the words are in different lexical classes, this proposal could be investigated by seeing if longer words fall into the three classes, too.

Otherwise, it will be difficult to easily identify a convincing case of lexical secondary stress – there are too many other ways of generating ‘fake’ cases, so any argument must carefully eliminate all other possible explanations.

Of course, one issue looms over this entire discussion: whether reported secondary stresses really exist. Secondary stress often has no phonetic realization, and descriptions rarely specify exactly how secondary stress is realized (see discussion in de Lacy 2014). It is possible, then, that many reported cases of secondary stress are actually artefacts of the perceptual systems of the grammar author. In the future, I hope that either phonological or phonetic evidence (and ideally both) will be provided as a precursor to any claim about secondary stress, rather than impressionistic reports alone.

I should add that if lexical secondary stress does exist, it is rather trivial to extend the theory suggested here. If underlying stress can be realized as secondary stress (as suggested for some Turkish dialects), then it is possible that the feature [stress] could be realized on any foot DTE, regardless of whether it is the PrWd DTE. Alternatively, [stress] could be multivalued, as in SPE. However, I am not aware of any convincing cases, so at the moment it seems reasonable to assert that there is never any underlying specification of

secondary stress, or any computational pressure to realize underlying [stress] on non-PrWd DTEs.

4. [Stress] Morphemes

If there is a feature [stress], one could expect it to behave like other segmental features morpho-phonologically. Other features can be part of phonologically impoverished segments, and even be the sole exponent of morphemes. Such morphemes can trigger mutation, and seek out particular segmental environments. This section argues that the [stress] feature theory provides a coherent formal account of morphemes that consist of stress alone, and explains why pre-stressing and post-stressing morphemes always involve primary stress.

4.1 Afar's [stress] Morpheme

Previous research has established that there are morphemes that consist of a single feature, or a featurally impoverished segment (Akinlabi 1996). Here, it is argued that there is a morpheme in Afar that consists of a single root node with the feature [stress] (for a different analysis, see Ulfsbjorninn 2016). Bliese (1981)'s description is adopted here; all page numbers refer to that work.

There are two classes of nouns in Afar: masculine and feminine. They are easy to distinguish by their morphological behavior: masculine nouns appear with masculine verb agreement, and feminine nouns take feminine agreement (e.g. [amo t-an] 'head_{FEM} FEM-be' 'There is a head' cf. [ħa.gid j-an] 'business_{MASC} MASC-be' 'There is business' – p.180).

Masculine nouns exhibit the default word-level prosodic structure of Afar – a quantity-sensitive right-aligned trochee. The data in (5) is from p.162 unless otherwise stated; all foot structure is my own.

- (5) *Afar masculine nouns* (L=(C)V, H=(C)VC or (C)V:)
- (a) LL: [(¹ʕa.ku)] 'thinness', [(¹ba.ra)] 'night', [(¹gi.ta)] 'road'
 - (b) LH: [mu(¹tuk)] 'butter', [a(¹raħ)] 'place', [ħu(¹sul)] 'meter'
 - (c) HL: [(¹na:fi)] 'dew', [(¹hor)ra] 'men's song', [(¹ħam)du] 'thanks' (24)
 - (d) HH: [nam(¹maj)] 'second', [mo:(¹tar)] 'car' (179)
 - (e) LLL: [ba(¹ħa.ri)] 'meadow' (181)
 - (f) LLH: [ka.ra:(¹rat)] 'mirror' (17)
 - (g) σHL: [ger(¹sit)tu] 'another' (181)

In contrast, feminine nouns all surface with a final stressed short vowel, as in (6).

(6) *Afar feminine nouns*

- (a) LL: [a.'mo] 'head', [ħa.'do] 'meat', [ħa.'le] 'mountain', [ba.'ða] 'daughter' (21)
- (b) HL: [ba:r.'ra] 'woman', [ħat.'ri] 'perfume', [duj.'je] 'stuff' (172)
- (c) LLL: [ħe.re.'ja] 'warthog' (15)
- (d) σHL: [ru.ga:.'ge] 'calf' (180), [ħa.da:.'ga] 'market' (22), [ul.lul.'lu] 'slope' (166)
- (e) HLL: [cam.mu.'re] 'cloud' (11)

Crucially missing from feminine nouns are forms that end in a heavy syllable (H, σH, σσH); in other words, all feminine nouns end in a short stressed vowel.

The evidence for Bliese (1981)'s description of stress is not just impressionistic: many morphemes exhibit stress-sensitive behavior, and mid vowels can appear stem-finally only if they are stressed (p.180). For example, certain animate nouns can appear in both feminine and masculine forms: e.g. [dum.'mu]_F, [dum.mu]_M 'cat'; [ka.taj.'sa]_F, [ka.'taj.sa]_M 'friend' (181). As expected, final mid vowels become high in masculine forms: /ħabule+FEM/ → [ħa.bu.'le]_F, but /ħabule+MASC/ → [ħa.'bu.li]_M 'insane person'; also [di.rab.'le]_F, [di.'rab.li]_M 'liar' (p. 181).

In the present theory, the Afar feminine morpheme is a suffix that consists of a root node with a [stress] feature: $\acute{\circ}$. As an example, /ħale₁+ $\acute{\circ}$ ₂/ surfaces as [ħa.'lé_{1,2}], where the suffix's featurally minimal root node merges with the preceding segment. An analysis is sketched in tableau (7).

(7) *Afar feminine*

/ħa ₁ le ₂ + $\acute{\circ}$ ₃ /	IDENT [stress]	DEP- FEATURE	ALIGN-R (FEM,PRWD)	FOOT FORM
(a) (ħa ₁ .lé _{2,3})				*
(b) (ħa ₁ .le _{2,3})	*!			
(c) (ħa _{1,3} .le ₂)			*!	
(d) ħa ₁ (le ₂ .í ₃)		*!		*

An important property of the Afar feminine [stress] morpheme is that it *must* appear at the right edge of the root. This requirement is enforced by the constraint ALIGN-R(FEM,PRWD) which requires the feminine's root node to be the rightmost root node in its PrWd.³

³ ALIGN-R(FEM,PRWD) is a rather brute-force constraint. It is possible that the right edge of every PrWd must align with the right edge of a stem-final morpheme in Afar, but evidence for such a claim would take us too far afield here.

- *No consonant-final feminine forms*

A striking consequence of the right-alignment requirement is that there can be no consonant-final feminine forms: e.g. *[butúk_{FEM}].⁴ Underlying /butu₁k₂+[◌]₃/ cannot surface as *[bu.¹tu₁k_{2,3}] because the PrWd DTE [u] does not bear the [stress] feature. It also cannot surface as *[bu.¹tu_{1,3}k₂] because the feminine morph is not rightmost in this form. Unfortunately, there are no alternations (and can be none) that show exactly what happens to final consonants when the feminine is attached. In tableau (8), it is assumed that they are deleted.

(8) *Afar feminine: Consonant-final roots are altered*

/bu ₁ tu ₂ k ₃ + [◌] ₄ /	ALIGN-R (FEM,PRWD)	MAX-C	FOOT FORM
(a) (bu ₁ . ¹ tú _{2,4})		*	*
(b) bu ₁ (¹ tú _{2,4} k ₃)	*!		
(c) (¹ bú _{1,4} .tu ₂ k ₃)	*!		

Long vowels are not permitted word-finally except in monosyllables (Bliese 1981:225). So, it is impossible to know exactly what happens to forms with demonstrably underlying final long vowels when the feminine morpheme attaches.

- *Alternatives*

An alternative analysis is that there is no feminine morpheme, but rather so-called ‘feminine’ nouns are simply those that have underlying final stress.

Such an analysis faces three problems. One is that ‘feminine’ is clearly a lexical class because feminine nouns match with feminine agreement on other items in their noun phrase: e.g. [ˈbaɖa-w] ‘son_M+vocative_M’ cf. [dum¹mu-j] ‘cat_F+vocative_F’ (183).

Another challenge is that it is not *roots* that are marked as feminine, but rather words: the feminine morpheme’s stress falls on the rightmost vowel in the PrWd, which sometimes belong to a suffix.

For example, the ‘Particular’ noun suffix /-jta/ attaches to masculine nouns and stress falls as expected: [(¹dum)mu] ‘tomcat_M’ cf. [dum(¹mu-j)ta] ‘particular tomcat’; [wa(¹kali)] ‘companion’ cf. [waka(¹li-j)ta] ‘particular companion’, [ɦu(¹tuk)] ‘start’ cf. [ɦu(¹tuk)-ta] ‘particular star’ (p.175). However, when the Particular is suffixed to feminine forms, the final vowel of the suffix is always stressed: [ga.ɣam.¹bo] ‘bread’ cf. [ga.ɣam.bo-j.¹ta] ‘particular bread’; [ɦa.¹le] ‘mountain’ cf. [ɦa.le-j.¹ta] ‘particular mountain’, [dum¹mu] ‘vixen’ cf. [dum.mu-j.¹ta] ‘particular vixen’. Here, it is possible that the Feminine’s morph follows the Particular’s morph underlyingly: e.g. /dummu₁-jta₂-[◌]₃/

⁴ Bliese (1981:180) notes a few exceptions in the Aussa dialect: e.g. [mo:¹tar] ‘car’, [um¹mat] ‘people’. For at least some animate nouns, consonant-final forms can take feminine agreement (p.182), though it is not clear whether the noun itself is marked as feminine.

→ [dummu₁-j^{tá}_{2,3}], *[dum^{mú}_{1,3}-jta₂]. Alternatively, the need for the Feminine morph to be rightmost in its PrWd may force it to appear at the right edge.

Similarly, the ‘abstract’ marker /i:no/ receives penultimate stress with masculine nouns as expected (e.g. [ab(^{b-i}:)nu] ‘responsibility’, [ka.taj(^{s-i}:)nu] ‘friendship’), but the feminine forces it to have final stress: e.g. /inki_F-i:no-^é_F/ → [inki:^{nó}] ‘singularity’; /man_{OF}-i:no-^é_F/ → [mani:^{nó}] ‘life’ (184). Finally, the feminine follows the plural: /am_{OF}-VCa-^é/ → [amo:^{má}] head-PL-FEM ‘heads’, /gile_F-CVa-^é/ → [gile:^{lá}] knife-PL-FEM ‘knives’ (177).

Finally, animate masculine nouns can become feminine: e.g. [ka^{tajsa}] ‘male friend’ ~ [kataj^{sa}] ‘female friend’ (p.181). Here, the meanings ‘female’ and ‘male’ are clearly attached to the masculine and feminine morphemes, respectively, and the final stress of the feminine form clearly cannot be analyzed as underlying – it must be introduced by a morpheme.

So, proposing that the Afar feminine is /^é/ provides a straightforward analysis. The [stress] feature is preserved in the same way as other segmental features (through an IDENT constraint). The Afar feminine is thus an unremarkable morpheme, formally speaking.

• *Nominative*

Like the feminine, the nominative suffix is also featurally defective. It consists of a root node that has three features: [stress], [+high], and [–round] (symbolized here as /^é/). So, it merges with the final vowel of a masculine root: /gita-^é/ → [gi^{tí}] ‘road’_M, /buuti-^é/ → [buu^{tí}] ‘pot’_M (p.164).

However, like the feminine, the nominative must be rightmost in its stem. Consequently, it deletes when it is faced with attachment to consonant-final masculine roots: e.g. /rusas-^é/ → [ru.^{sas}] ‘bullet’_M, *[ru.^{sís}]; /marub-^é/ → [ma.^{rub}] ‘sheep’_M, *[ma.r**í**b].

The nominative also cannot attach to feminine roots: e.g. /naʕna₁-^é₂-^é₃/ → [naʕná_{1,2}], *[naʕní_{1,2,3}], *[naʕní_{1,3}]. In this situation, coalescence of the feminine with the nominative would obliterate any distinctive realization of the feminine in the output, falling afoul of constraints that require that at least some element of a morpheme have an independent exponent (e.g. Wolf 2005).

The importance of the Afar nominative is that it combines [stress] with other segmental features ([high], [round]), just as one would expect of a segmental feature (for detailed examples, see Akinlabi 1996, de Lacy 2012).

• *Prosodic Conceptions of the Feminine*

In theories that permit underlying prosodic structure and have no feature [stress], the Afar feminine would have to underlyingly consist of a head mora of a head syllable of a head foot (/ú/): e.g. /butu+ú/ → [bu.^{tú}], where the mora docks onto the rightmost vowel (and/or

merges with the rightmost underlying mora).⁵ In contrast, a theory without underlying prosodic structure and the feature [stress] must claim that the Afar feminine morpheme is a root node with a feature [stress].

There is evidence that the feminine does in fact contain a root node. The postposition /-k/ ‘genitive’ appears as [k] *except* with some feminine roots. When it suffixes to a feminine root, it remains [k] before a vowel-initial word, but geminates the following consonant when consonant-initial words follow: e.g. /amo₁-[•]₂-k inti/ → [a.¹mó_{1,2}.kin¹ti] ‘a head’s eye’, /rejta₁-[•]₂-k mojjá/ → [rej¹tá_{1,2}m:oj¹ja] ‘a goat’s skull’ (170). The genitive /k/ remains faithful elsewhere: e.g. [da¹nán-a-k řabál] ‘donkey-GEN blood’ ‘blood of a donkey’ – the only place where it geminates is between a feminine stressed syllable and a consonant.

As established above, the feminine morpheme seeks to be the rightmost root node in its PrWd. Before vowel-initial roots, syllabifying the [k] into the following PrWd allows the feminine root node to be final: [{a.¹mó_{1,2}} {kin.¹ti}]. However, the genitive /k/ cannot be pushed into the following PrWd when that PrWd already starts with a consonant because complex onsets are not permitted. The solution is for the /k/’s root node to delete, ending up with a geminate consonant: [rej.¹tá_{1,2}m:ojjá]. The output structure is schematized in

(9). Deletion of the /k/’s root node means that it is no longer – strictly speaking – the rightmost root node in the leftmost PrWd: the rightmost root node that belongs *fully* to the first PrWd is [á_{1,2}]. In other words, by geminating the final consonant, the feminine becomes the rightmost root node.

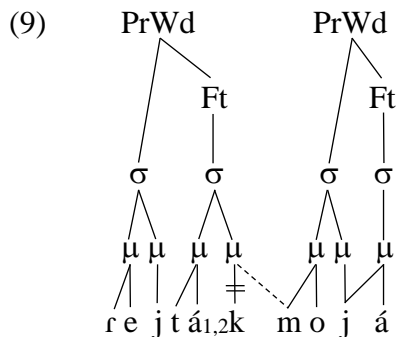

The same behavior is found with other morphemes. With feminine forms, another genitive morpheme surfaces as [h] before vowel-initial words, and as a geminate elsewhere: /saga_F-[•]₁-[•]₂-h iba/ → [{sa¹gá} {h¹iba}] ‘foot-FEM-NOM-GEN cow’ (‘cow’s foot’), cf.

⁵ The feminine could not simply be a head foot node (F¹). If it were, there would be no problem with /butuk+F¹/ → [bu(‘túk)] as the feminine’s foot node is rightmost in the word. If the feminine was instead a head syllable node (σ), the same problem arises. So, in a prosodic analysis the feminine morph must at least consist of a head mora of a head syllable.

/buɖaF-**•**-h mara/ → [{{bu'dám}}{'á:ra}] ‘people-FEM-GEN village’ (‘villagers’) (165). Again, the feminine ends up as the rightmost root node that is fully contained in its PrWd.

Could the same restriction be explained if the feminine was a prosodic structure? If the feminine was /**•**ú/, as defined above, there is a challenge to explaining why /-k/ and /-h/ geminate before consonant-initial words. Firstly, the feminine’s **•** must be required to be final in its PrWd to explain why the feminine cannot attach to consonant-final stems: i.e. /butu₁k₂-**•**ú₃/ → *[butú_{1,3}k₂], *[butu₁k_{2,3}]. However, for /rejta-k moj:a/, geminating the /k/ to form [rej'tám:oj:'a] does not make the feminine’s mora rightmost: as seen in (9), the genitive’s mora is still rightmost in the PrWd even after delinking its root node. In other words, if the feminine is a mora /**•**ú/, geminating the /k/ and /h/ morphemes serves no purpose as it does not allow the feminine’s morph to align with the PrWd’s right edge.

The solution for the prosodic analysis could simply be to extend the morpheme so that it includes a root node: i.e. the feminine morph would consist of a head root node dominated by a head mora dominated by a head syllable (and perhaps by a head foot). Then, the root node could be required to be rightmost, providing the same analysis as above. However, it is striking that the [stress] theory necessitates a root node, and provides a straightforward account of the Afar feminine’s behavior, while a prosodic conception of a ‘stress morpheme’ must resort to a surprisingly elaborate structure.

4.2 Pre- and Post-stressing Morphemes

Some morphemes combine fully specified segments with partially specified root nodes that bear [stress]. Such morphemes either attract stress away from the default position or other lexical positions (i.e. ‘pre-stressing’ and ‘post-stressing’ morphemes), or their morphs travel to the default stress position (infixing), or they only ever appear next to stressed syllables.

For example, the construct state infix in Ulwa suffixes to the primary stressed syllable (McCarthy & Prince 1993:112, Green 1999:52). In present terms, the morpheme is underlyingly /**•**ka/. Footing is iambic, starting at the left edge; the head foot is leftmost: e.g. /siwa₁nak-**•**2ka/ → [(si'wá_{1,2})kanak] ‘root’; /ana:1la:ka-**•**2ka/ → [(a'ná:1,2)kala:ka] ‘chin’.

Forms like /kara₁smak-**•**2k₃a/ → [(ka'rá_{1,2s})k₃amak] ‘knee’ illustrate an important point about the present theory: adjacency requirements can be relaxed in some grammars, as in [...á_{1,2}sk₃]. In Ulwa, the suffix’s root node /**•**/ can end up separated from its following underlying segment if syllable and foot requirements force it: e.g. the adjacency-preserving *[ka'rá]kasmak] is less optimal than the winner [(ka'rás)kamak] because it lacks a heavy foot head.

Pre- and post-stressing morphemes have the same underlying form as Ulwa’s construct state infix; they differ in that instead of the morph moving to the stressed syllable, the stressed syllable moves to the morph. For example, the Modern Greek genitive singular is a pre-stressing morpheme (Revithiadou 1999§2.2.1): i.e. /**•**u/. So, while stress usually falls on the antepenultimate syllable, it is attracted to the penult in /anθro1p-**•**2u/ → [anθ'ró_{1,2p}-u], *['anθro_{1,2p}-u].

Finally, morphemes that only attach to stressed syllables also have an underlying defective root node with [stress]. For example, the American English noun-attaching *-ful* only suffixes to words whose last syllable has main stress (Siegel 1974:168-174). Examples include [ˈpɪs-fl] ‘peaceful’, [səˈspɛns-fl] ‘suspenseful’, [ˌdɪs.rəˈspɛkt-fl] ‘disrespectful’, and not *[ˈwɪz.dəm-fl] ‘wisdomful’, *[wɪk.nəs-fl] ‘weaknessful’, *[ˌɪnˈvɛntʃən-fl] ‘inventionful’. In present terms, the suffix is underlyingly /●fl/. When it cannot attach to a final main-stressed syllable, it is blocked from appearing.

So, in the present theory, the representation of pre-/post-stressing morphemes, stress-seeking infixes, and affixes that only appear adjacent to a stressed syllable is the same: the underlying fully specified string is preceded (or followed) by a ●. Exactly how the grammar behaves depends on how default footing is favored with respect to affix edge alignment and morph realization.

The present theory makes a strong prediction about such morphemes: all of them must require primary stress (i.e. PrWd DTE). There can be no pre-stressing suffix that induces secondary stress, or any affix that seeks out a secondary stress position, or must attach to a secondary stress. Such an affix would be impossible to represent in the current theory since [stress] is only compatible with PrWd DTEs (i.e. primary stress). The correctness of this prediction awaits a thorough review of all such morphemes.

Prosodic accounts of stress-related morphemes face some formal challenges. Suppose the Modern Greek genitive singular is /σu/, where /σ/ is a prosodic structure consisting of a head syllable node. How does such a representation induce stress on the preceding syllable? To do so, the adjacency and precedence relations between the /σ/ and /u/ must be preserved. Unfortunately, that not possible: there is no precedence or adjacency relation between the σ node and the /u/’s root node – they are on different tiers. Since there is no relation to preserve, the morpheme’s /σ/ should be free to float to any position; in fact, as there is no motivation for it to appear on the immediately preceding syllable, it should move to the default stress position.

There are several imaginable ways to avoid this problem. One is to propose that the /u/ also has a syllable node /σuσ/, and so the order between the syllables is preserved. However, preserving /σ/ nodes brings the theory dangerously close to allowing contrastive syllabification. Another option would be to say that the underlying form consists of a root node that is the head of a head syllable. Then, for /●σu/, the immediate precedence relation between the /●/ and /u/ could be preserved.

A general issue relates to where the precedence relation holds. If precedence only holds between root nodes (and tones, presumably), any underlying prosodic structure would have to be anchored to a root node if it was to retain its underlying precedence and adjacency relations. If so, no morpheme that has segmental material could contain floating prosodic structure – every node would have to be anchored to a root node. So, the differences between specifying stress as a feature and a prosodic structure start to disappear: in both theories, stress is tied to the root node tier. A remaining issue for the

prosodic theory is how to account for the lack of pre- and post-stressing morphemes that induce secondary stress.

4.3 Lexical Non-stress

The present theory predicts that there should be no lexical contrast involving unstressed syllables: the [stress] feature is privative and there is no active preservation of underlying lack of [stress]. This prediction is the same as in Alderete (1999)'s theory, where underlying prominence is preserved, but not lack of prominence. However, if [stress] was a binary feature [\pm stress], where a [-stress] segment was required to appear inside a segment that is not a foot DTE and some constraint preserved underlying [-stress], then one should expect to find detectable effects: i.e. morphemes that repel stress from particular positions. Revithiadou (1999) proposes a relevant system, with two possible values for lexical stress – accented and unaccented.

In practice, it is very difficult to detect lexical non-stress because it behaves much like lexical stress. For example, suppose there is an underlyingly unstressed suffix /-tĩ/. In a language with final stress, -ti would repel stress onto the penult: [pu'ka] cf. [pu'katĩ]). However, such a pattern admits a variety of other analyses, such as -ti being pre-stressing, or attaching outside the stem's PrWd (e.g. Kabak & Vogel 2001), or provoking faithfulness to the base's stress position (e.g. Benua 1997; section 3.2 above).

More easily detectable cases of underlying unstress would involve pre-unstressed suffixes. For example, suppose a language had consistently final stress, but there was a suffix /-tĩ/ that forced stress retraction: e.g. [pu'ka] vs. [pukă-tĩ] – stress is forced off not only the suffix here, but also kept off the preceding vowel of the root.

I have not found any such cases. However, Revithiadou (1999) argues that Thompson River Salish (Nleʔképmx) preserves underlying unstress. By default, stress falls on the leftmost full vowel, otherwise the rightmost [ə]. However, there are unaccentable roots that repel stress: e.g. [meloq'w-e-s-'t-es] 'knock someone out', [q^wi.n-əm] 'serve as a spokesman', [cuwes=^lxən] 'measure another shoe' (R44).

What complicates matters here is that there are alternative analyses of the Thompson River Salish metrical system, such as Coelho (2002)'s (C). In C's analysis, morphemes are lexically specified as underlyingly stressed or lacking stress – in present terms, some morphemes have any underlying root node with [stress] and others do not. In effect, surface stress falls on the rightmost suffix with underlying stress. If there are no suffixes with underlying [stress], stress falls on the first suffix.

Crucial to C's analysis is a constraint that is violated when an output segment is stressed but its input correspondence is not. In the present theory, such a constraint is OI-IDENT[stress] "If output *x* contains [stress], then input *x*' contains [stress]." At first glance, such a constraint seems to have an effect very like preservation of lack of stress. However, its effect is slightly different: it favors output stress falling on a segment that had underlyingly [stress], but it does not specifically preserve unstress.

The difference is most clearly visible if there is a three-way distinction between underlying stress, unstress, and lack of specification. Returning to the example with

/puka-^htí/, IO-IDENT-unstress would favor ['pukati] over [puka'ti] and [pu'kati] as the latter two fail to preserve the underlying lack of stress. Of course, this is an undesirable result since such 'pre-unstressing' suffixes do not seem to exist. In contrast, IO-IDENT[stress] and OI-IDENT[stress] assign the same violations to all three forms, and so are irrelevant in this competition.

A complete evaluation of C's analysis of Thompson River Salish is beyond the space and scope of this paper. It is simply noted here that with a privative stress feature and preservation of [stress] on both IO and OI dimensions, effects somewhat like – but not entirely the same as – preservation of unstress can be produced. Consequently, any apparent preservation of stresslessness requires careful evaluation and consideration of alternative analyses.

5. Conclusions

This article provided part of an argument that there is no prosodic structure in lexical entries. Without underlying prosodic structure, contrastive stress requires a feature [stress] and constraints that preserve it (IDENT[stress]). In the output, only PrWd DTEs can bear the [stress] feature. A consequence is that there can be no lexical secondary stress, no morphemes that require secondary stress to follow/precede them, and no morphemes that seek to attach to secondary stressed syllables. The next step is to show that there are no underlying moras, a task I leave for future work.

Finally, it is now possible to return to the issue of representational redundancy, raised in section 1. Here, it has been argued that while [stress] and prosodic structure do the same representational work in the output, they have different roles in input-output preservation. As there is no underlying prosodic structure, all stress-related contrast is due to the feature [stress]. This point emphasizes that appealing to representational redundancy is a complicated matter: truly redundant features/structures must be redundant in terms of the output, input-output preservation, and computation, as well as being representationally duplicative. Consequently, the [stress] feature is only a partially redundant representational entity: its value is in accounting for contrast, something that prosodic structure cannot be used for.

References

- Akinlabi, A. (1996). Featural alignment. *Journal of Linguistics* 32: 239-289.
- Alderete, John (1999). *Morphologically governed accent in Optimality Theory*. Doctoral dissertation, University of Massachusetts, Amherst.
- Bauer, W., W. Parker and Te K. Evans (1993). *Maori*. London and New York, Routledge.
- Bennett, R. (2013). The uniqueness of metrical structure: rhythmic phonotactics in Huariapano. *Phonology* 30: 355-398.
- Benua, L. (1997). *Transderivational identity: phonological relations between words*. Doctoral dissertation, University of Massachusetts Amherst.

- Bliese, L. (1981). *A generative grammar of Afar*. SIL publications in linguistics. Dallas, SIL/Arlington, Texas: University of Texas at Arlington.
- Bolozky, S. (1982). Remarks on rhythmic stress in Modern Hebrew. *Journal of Linguistics* 18: 275-289.
- Chomsky, N. and M. Halle (1968). *The sound pattern of English*. New York, Harper & Row.
- Coelho, Gail (2002). Conflicting directionality in Thompson River Salish. In Augustine Agwuele & Hansang Park (eds.) Proceedings of the Texas Linguistics Society VII. http://tls.ling.utexas.edu/2002tls/TLS_2002_Proceedings.html
- de Lacy, Paul (2004). Maximal Words and the Māori passive. In John McCarthy (ed.) *Optimality Theory in phonology: A reader*. Blackwell, pp. 495-512.
- de Lacy, Paul (2006). *Markedness: Reduction and Preservation in Phonology*. Cambridge Studies in Linguistics 112. Cambridge University Press.
- de Lacy, Paul (2007). Freedom, Interpretability, and the Loop. In Sylvia Blaho, Patrik Bye, and Martin Krämer (eds.). *Freedom of Analysis? Studies in Generative Grammar (SSG) 95*. Mouton de Gruyter, pp. 86-118.
- de Lacy, Paul (2009). Phonological evidence. In Steve Parker (ed.). *Phonological argumentation: Essays on evidence and motivation*. Equinox Publications, pp. 43-78.
- de Lacy, Paul (2012). Morphophonological polarity. In Jochen Trommer (ed.) *The morphology and phonology of exponence*. Oxford University Press, pp. 121-159.
- de Lacy, Paul (2014). Evaluating evidence for stress systems. In Harry van der Hulst (ed.) *Word stress: Theoretical and typological issues*, Cambridge, UK: Cambridge University Press, pp.149-193.
- de Lacy, Paul (2017). Circumscriptive haplologizing reduplicants. In Heidi Quinn, Diane Massam, and Lisa Matthewson (eds). *Linguistic Travels in Time and Space: Festschrift for Liz Pearce*. Wellington Working Papers in Linguistics (WWPL) 23: 41-52.
- Fabb, N. (1988). English suffixation is constrained only by selectional restrictions. *NLLT* 6.4:527-539.
- Gouskova, M. (2010). The phonology of boundaries and secondary stress in Russian compounds. *The Linguistic Review* 27.4: 387-448. doi:10.1515/tlir.2010.015
- Green, T. M. (1999). *A lexicographic study of Ulwa*. Doctoral dissertation, Massachusetts Institute of Technology.
- Halle, Morris & Michael Kenstowicz (1991). The Free Element Condition and cyclic versus noncyclic stress. *Linguistic Inquiry* 22:457-501.
- Hayes, Bruce (1995). *Metrical Stress Theory: principles and case studies*. Chicago, University of Chicago Press.
- Hill, J.H. (2005). *A grammar of Cupeño*. University of California Publications in Linguistics 136. Berkeley and Los Angeles, CA: University of California Press.

- Hulst, H. van der (1994). Separating Primary and Secondary Stress. Ms., University of Leiden.
- Inkelas, S. and C. Zoll (2007). Is grammar dependence real? A comparison between cophological and indexed constraint approaches to morphologically conditioned phonology. *Linguistics* 45.1: 133-171.
- Itô, J. & A. Mester (1995). Japanese phonology. In John Goldsmith (ed.) *The handbook of phonological theory*. Oxford, U.K., Blackwell, pp.817-838.
- Kabak, B. & I. Vogel (2001). The phonological word and stress assignment in Turkish. *Phonology* 18.3: 315-360.
- Ketner, K.H. (2006). *Size Restrictions in Prosodic Morphology*. Doctoral dissertation, the University of Cambridge.
- Kenyon, J. & T. A. Knott (1953). *A pronouncing dictionary of American English*. Fourth edition. Springfield, MA.: Merriam.
- Kiparsky, P. (2003). Finnish Noun Inflection. In S. Manninen & D. Nelson (eds.) *Generative Approaches to Finnic and Saami Linguistics*. Stanford, CA: CSLI Publications, pp. 109-161.
- Levin, Juliette (1985). *A metrical theory of syllabicity*. Doctoral dissertation, MIT.
- Liberman, Mark and Alan Prince (1977). On stress and linguistic rhythm. *Linguistic Inquiry* 8: 249-336.
- Lynch, John (1978). *A Grammar of Lenakel*. Pacific Linguistics B. Canberra, Australian National University.
- McCarthy, J. J. (1988). Feature geometry and dependency: a review. *Phonetica* 43: 84-108.
- McCarthy, J. J. (2005). Optimal Paradigms. In Laura J. Downing, T.A. Hall, and Renate Raffelsiefen (eds.), *Paradigms in Phonological Theory*. Oxford: Oxford University Press, pp. 170-210.
- McCarthy, J. J., and A. Prince (1993). *Prosodic Morphology I: Constraint Interaction and Satisfaction*. Ms., University of Massachusetts Amherst and Rutgers University, New Brunswick, NJ. Rutgers Optimality Archive 482.
- McCarthy, John J. and Alan Prince (1999). Faithfulness and identity in Prosodic Morphology. In Rene Kager, Harry van der Hulst and Wim Zonneveld (eds.) *The Prosody-Morphology Interface*. Cambridge, CUP, pp.218-309.
- Özçelik, Ö. (2014). Prosodic faithfulness to foot edges: the case of Turkish stress. *Phonology* 31: 229-269.
- Parker, S. (2013). Disjoint Metrical Tiers and Positional Markedness in Huariapano (Panobo). *GAILens* 7.1. <http://www.gial.edu/gialens/vol7num1/>
- Pater, Joe (2000). Nonuniformity in English secondary stress: the role of ranked and lexically specific constraints. *Phonology* 17: 237-274.
- Revithiadou, A. (1999). *Headmost accent wins*. Doctoral dissertation, Leiden University.

- Schütz, A. J. (1978). English Loanwords in Fijian. In A. J. Schütz (ed.) *Fijian Language Studies: Borrowing and Pidginization*. Bulletin of the Fiji Museum 4, Suva: Fiji Museum.
- Siegel, D. (1974). *Topics in English Morphology*. Doctoral dissertation, MIT.
- Smith, J. L. (2002). *Phonological augmentation in prominent positions*. Doctoral dissertation, University of Massachusetts Amherst.
- Stanton, J. and S. Zukoff (2018). Prosodic identity in copy epenthesis: Evidence for a correspondence-based approach. *Natural Language and Linguistic Theory* 36.2: 637-684.
- Ulfsbjorninn, S. (2016). Towards Eradicating Class Driven Allomorphy: Nominal Suffixes in Afar. Ms. University of Lyon and University College London. <https://ling.auf.net/lingbuzz/003533>
- Voegelin, C.F. (1935). *Tübatulabal Grammar*. University of California Publications in American Archaeology and Ethnology 34.2: 55-190. Berkeley, CA: University of California Press.
- Wolf, M. (2005). An Autosegmental Theory of Quirky Mutations. In J.Alderete, C.Han, and A.Kochetov (ed.) *Proceedings of the 24th West Coast Conference on Formal Linguistics*, pp.370-378. Somerville, MA: Cascadilla Proceedings Project.
- Zukoff, S. (2015). Stress restricts reduplication. In AMP 2014. Washington, DC: Linguistic Society of America.
- Zuraw, K. (2002). Aggressive reduplication. *Phonology* 19: 395-439.

Paul de Lacy
Rutgers, The State University of New Jersey
Linguistics Department
18 Seminary Place
New Brunswick, NJ
08901
U.S.A.
delacy@rutgers.edu
<http://www.pauldelacy.net>